

STYLE RCAFW

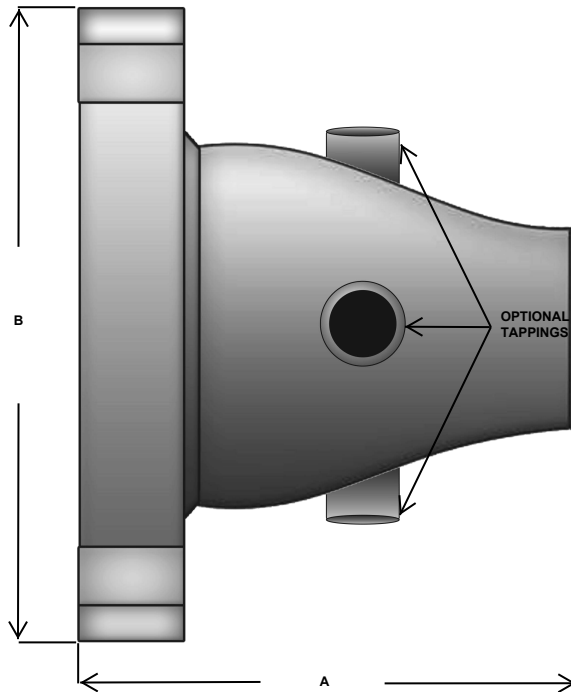

| | | | | | | | |
|-------------------------------------|----------------|----------|----------|--------------|-------------------|--------------|------------|
| STYLE: RCAFW | | | | | | | |
| DIMENSIONS (NOMINAL) | | | | | | | |
| 150# PLATE FLANGE X WELD END | | | | | | | |
| STRAIGHT REDUCER FLG X FLG | | | | | PART | | |
| LG END | SML END | A | B | BOLTS | NUMBER**** | PORTS | QTY |
| 2 1/2" | 1 1/4" | 3.75" | 7.00" | 4 | RCAFW2512XXXX | | |
| 2 1/2" | 1 1/2" | 3.75" | 7.00" | 4 | RCAFW2515XXXX | | |
| 2 1/2" | 2" | 3.75" | 7.00" | 4 | RCAFW2520XXXX | | |
| 3" | 1 1/2" | 3.75" | 7.50" | 4 | RCAFW3015XXXX | | |
| 3" | 2" | 3.75" | 7.50" | 4 | RCAFW3020XXXX | | |

| | |
|--------------------------------|---|
| SPECIFICATIONS | |
| PSI/TEMPERATURE RATING: | 125 PSIG @ 250 F. |
| BODY MATERIAL: | SCH. 40 CONCENTRIC REDUCER |
| BODY TAPPINGS: | 1/4"- 3/4" NPT 150# FEMALE COUPLINGS |
| FLANGE: | 150# PLATE FLANGE |
| WELD END: | SCH 40 CARBON STEEL |

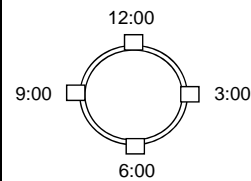

| | | | | | |
|--|------------|------------|------------|------------|--|
| **LAST FOUR DIGITS XXXX ARE FOR OPTIONAL PORTS & LOCATION. MUST FILL IN LAST FOUR DIGITS . | 1ST | 2ND | 3RD | 4TH | 0= NO TAPPING 1= 1/4" TAPPING 2= 1/2" TAPPING 3= 3/4" TAPPING |
| | 12:00 | 3:00 | 6:00 | 9:00 | |
| | X | X | X | X | |

DRAWN BY:

DRAWING NUMBER:

REV:

SIGNATURE:

DATE:

PO NUMBER:

PROJECT:

CUSTOMER:

NOTES: