

STYLE RCAFF

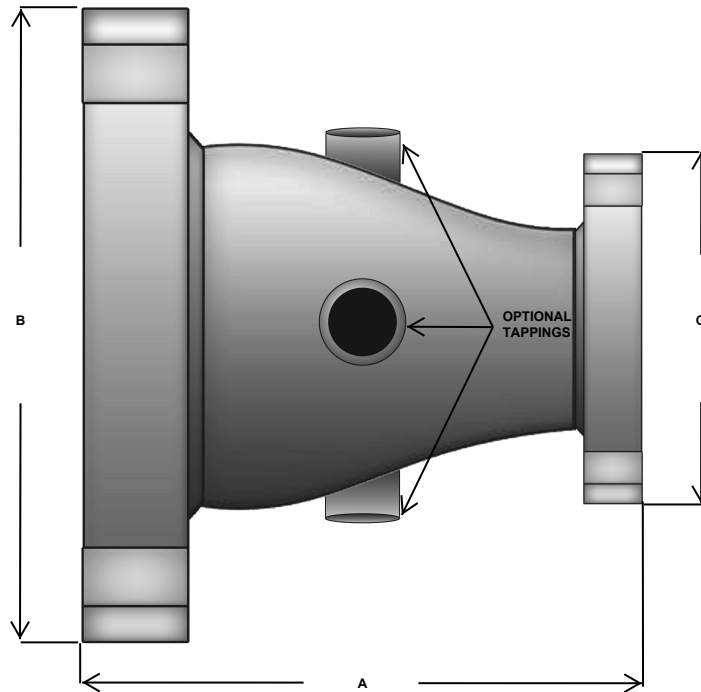

STYLE: RCAFF								
DIMENSIONS (NOMINAL)								
150# PLATE FLANGE X PLATE FLANGE								
STRAIGHT REDUCER FLG X FLG						PART		
LG END	SML END	A	B	C	BOLTS	NUMBER****	PORTS	QTY
3"	2 1/2"	4.00"	7.50"	7.00"	4/4	RCAFF0325XXXX		
4"	2"	4.50"	9.00"	6.00"	8/4	RCAFF0402XXXX		
4"	3"	4.50"	9.00"	7.50"	8/4	RCAFF0403XXXX		
6"	3"	6.00"	11.00"	7.50"	8/4	RCAFF0603XXXX		
6"	4"	6.00"	11.00"	9.00"	8/8	RCAFF0604XXXX		
6"	5"	6.00"	11.00"	10.00"	8/8	RCAFF0605XXXX		
8"	6"	6.50"	13.50"	11.00"	8/8	RCAFF0806XXXX		

SPECIFICATIONS	
PSI/TEMPERATURE RATING:	125 PSIG @ 250 F.
BODY MATERIAL:	SCH. 40 CONCENTRIC REDUCER
BODY TAPPINGS:	1/4" - 3/4" NPT 150# FEMALE COUPLINGS
FLANGES:	150# PLATE FLANGE

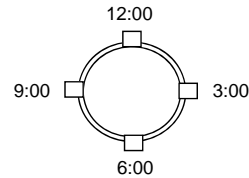

**LAST FOUR DIGITS XXXX ARE FOR OPTIONAL PORTS & LOCATION. MUST FILL IN LAST FOUR DIGITS .	1ST	2ND	3RD	4TH	0= NO TAPPING
	12:00	3:00	6:00	9:00	1= 1/4" TAPPING
	X	X	X	X	2= 1/2" TAPPING
					3= 3/4" TAPPING

DRAWN BY:

DRAWING NUMBER:

REV:

SIGNATURE:

DATE:

PO NUMBER:

PROJECT:

CUSTOMER:

NOTES: