

T2 PTFE EXPANSION JOINT

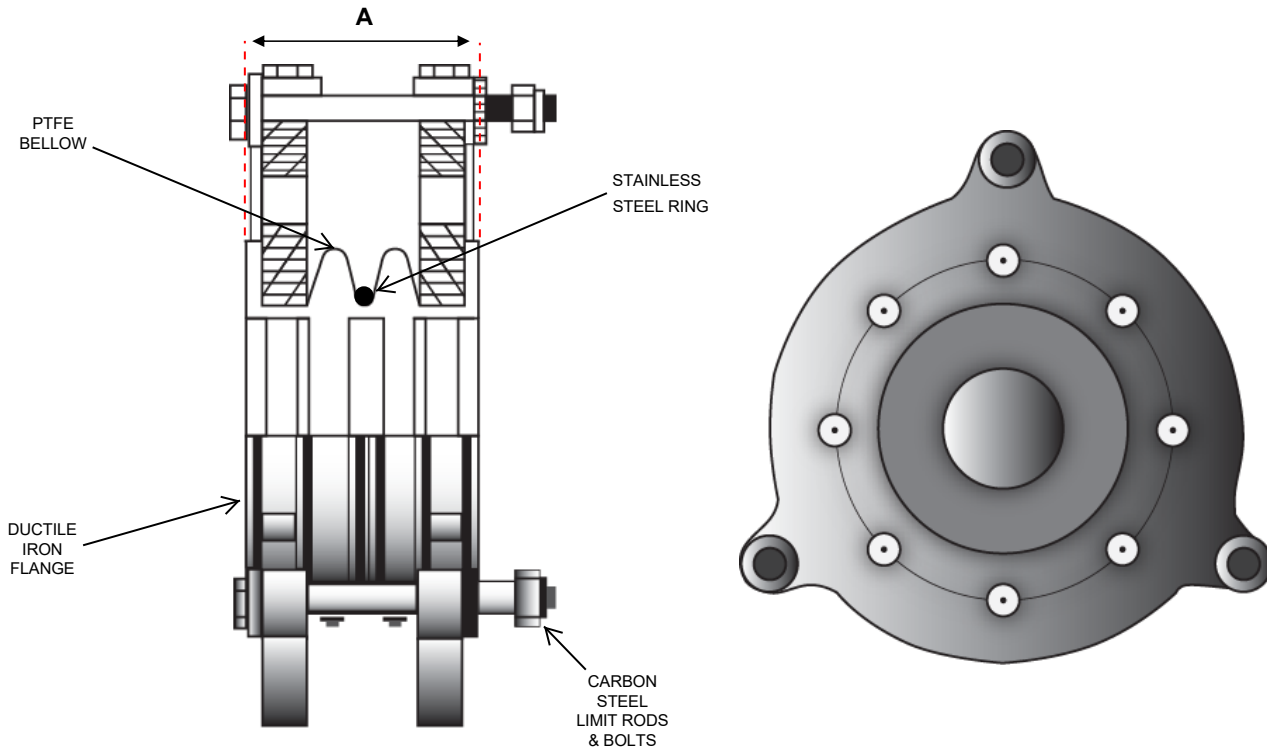

NOTE: FOR PROPER OPERATION ALL PIPING MUST BE PROPERLY ANCHORED AND GUIDED

| QTY | I.D. | MODEL NUMBER | "A" OAL | AXIAL MOVEMENT | LATERAL MOVEMENT | ANGULAR DEFLECTION | PSIG @ 70° F | WT. LBS. |
|-----|------|--------------|---------|----------------|------------------|--------------------|--------------|----------|
| | 1 | T2-100 | 1.375" | 0.25" | 0.125" | 7° | 185 | 2 |
| | 1.5 | T2-150 | 1.375" | 0.25" | 0.125" | 7° | 185 | 3 |
| | 2 | T2-200 | 1.563" | 0.25" | 0.125" | 7° | 185 | 7 |
| | 3 | T2-300 | 2.25" | 0.375" | 0.188" | 7° | 185 | 12 |
| | 4 | T2-400 | 2.625" | 0.5" | 0.25" | 7° | 185 | 18 |
| | 6 | T2-600 | 2.75" | 0.5" | 0.25" | 7° | 185 | 29 |
| | 8 | T2-800 | 4" | 0.5" | 0.25" | 7° | 164 | 47 |
| | 10 | T2-1000 | 5.25" | 0.5" | 0.25" | 7° | 164 | 64 |
| | 12 | T2-1200 | 6" | 0.5" | 0.25" | 7° | 59 | 88 |

DRAWN BY:

DRAWING NUMBER:

REV:

SIGNATURE:

DATE:

PO NUMBER:

PROJECT:

CUSTOMER:

NOTES: