

**TCHS - GRPF Metric**

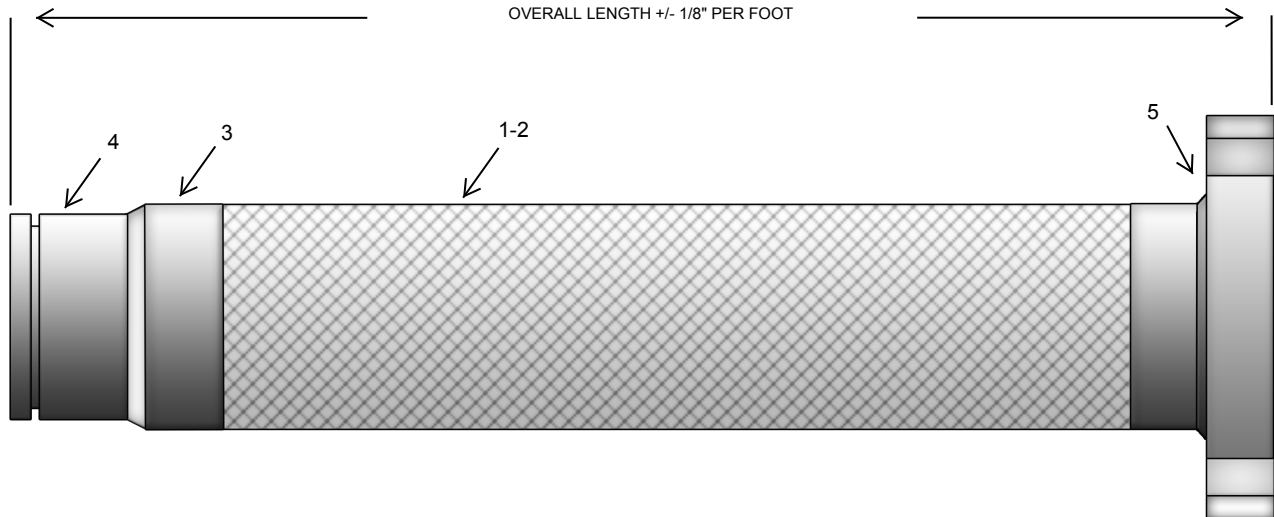

**MATERIALS**

- #1-2 HOSE & BRAID: STAINLESS STEEL HOSE WITH 1-LAYER OF STAINLESS STEEL BRAID
- #3 BRAID BAND: STAINLESS STEEL
- #4 END FITTING: SCH. 40 CARBON STEEL GROOVE
- #5 END FITTING: CARBON STEEL PLATE FLANGE 150# DRILL

QTY	MODEL NUMBER	SIZE	OVERALL LENGTH	MAX O.D.	PRESSURE (PSIG)		TEMP °C	MOTION LATERAL	WT. LBS.
					OPER.	TEST			
	TCHS-200-GRPF	50.8MM	304.8MM	62.484MM	370	555	21° C	9.525MM	10
	TCHS-250-GRPF	63.5MM	355.6MM	87.63MM	400	600	21° C	9.525MM	12
	TCHS-300-GRPF	76.2MM	355.6MM	101.854MM	288	431	21° C	9.525MM	13
	TCHS-400-GRPF	101.6MM	406.4MM	127.762MM	250	375	21° C	12.7MM	18
	TCHS-500-GRPF	127MM	431.8MM	154.94MM	200	300	21° C	12.7MM	25
	TCHS-600-GRPF	152.4MM	457.2MM	181.61MM	220	330	21° C	12.7MM	28
	TCHS-800-GRPF	203.2MM	508MM	239.776MM	215	323	21° C	12.7MM	50
	TCHS-1000-GRPF	254MM	609.6MM	291.846MM	200	350	21° C	19.05MM	70
	TCHS-1200-GRPF	304.8MM	635MM	343.154MM	160	240	21° C	19.05MM	90

DRAWN BY:

DRAWING NUMBER:

REV:

SIGNATURE:

DATE:

PO NUMBER:

PROJECT:

CUSTOMER:

NOTES: