

DOG LEG MMT 3"

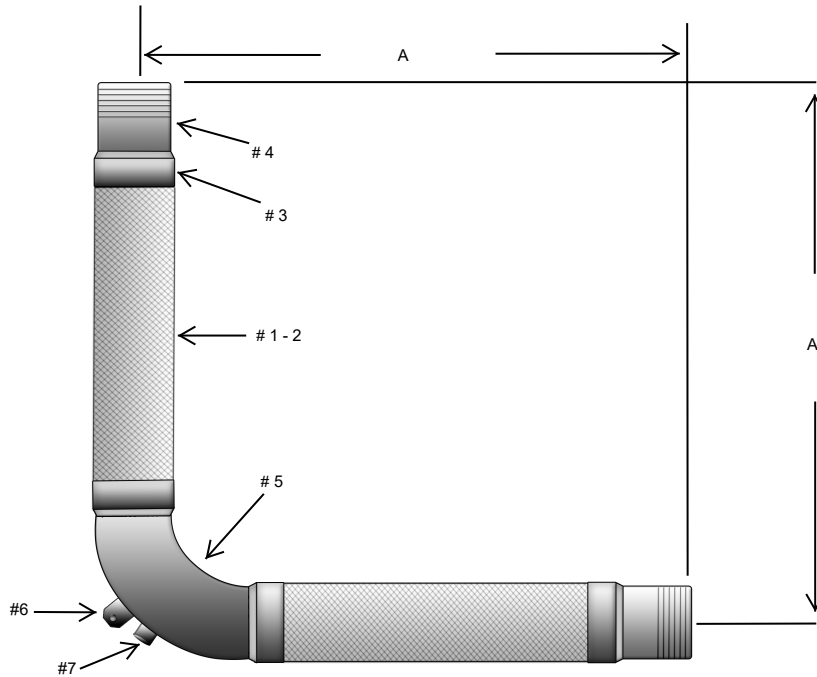

MATERIALS

- #1-2 HOSE: STAINLESS STEEL HOSE WITH 1-LAYER STAINLESS STEEL BRAID
- #3 BRAID BAND: STAINLESS STEEL
- #4 END FITTING: CARBON STEEL SCH. 40 MALE NPT
- #5 ELBOWS: CARBON STEEL SCH. 40
- #6 HANGER
- #7 PORT (OPTIONAL):

QTY	MODEL #	SIZE	"A" DIM.	WRK. PSIG	MAX TEST	@ TEMP.	LATERAL OFFSET
	TCH-SDL050013	1/2"	15 1/4"	1100	1650	70°F	3"
	TCH-SDL075013	3/4"	17"	597	895	70°F	3"
	TCH-SDL100013	1"	18"	580	870	70°F	3"
	TCH-SDL125013	1 1/4"	20 1/4"	441	661	70°F	3"
	TCH-SDL150013	1 1/2"	22 1/4"	370	555	70°F	3"
	TCH-SDL200013	2"	24 3/4"	370	555	70°F	3"
	TCH-SDL250013	2 1/2"	23 3/4"	400	600	70°F	3"
	TCH-SDL300013	3"	25 3/4"	288	431	70°F	3"

TEMPERATURE DERATING FACTORS: MULTIPLY X WRK. PSIG									
200° F	250° F	300° F	350° F	400° F	500° F	600° F	700° F	800° F	900° F
0.94	0.92	0.88	0.86	0.83	0.78	0.74	0.7	0.66	0.62

DRAWN BY:

DRAWING NUMBER:

REV:

SIGNATURE:

DATE:

PO NUMBER:

PROJECT:

CUSTOMER:

NOTES: