

DOG LEG MMT 2"

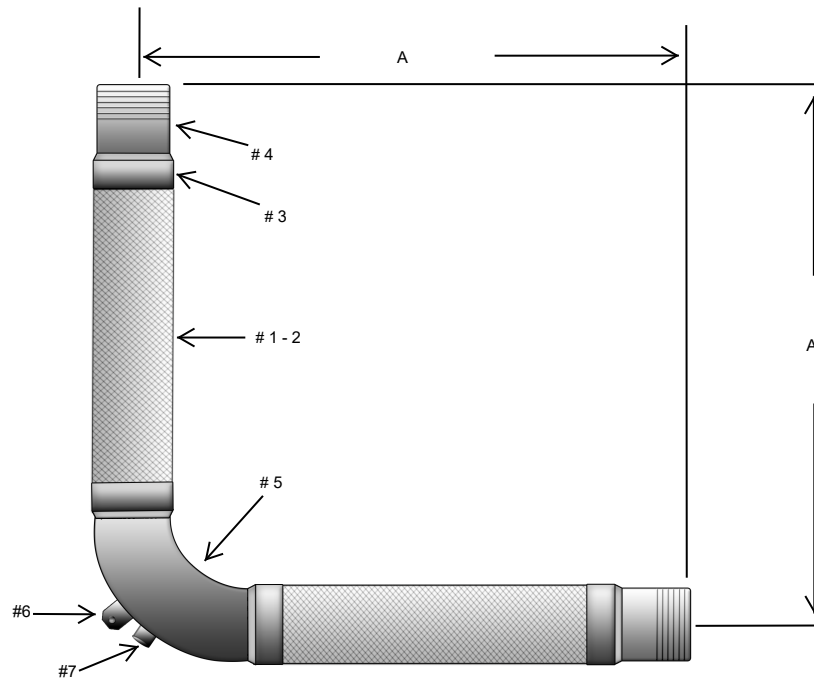

MATERIALS

- #1-2 HOSE: STAINLESS STEEL HOSE WITH 1-LAYER STAINLESS STEEL BRAID
- #3 BRAID BAND: STAINLESS STEEL
- #4 END FITTING: CARBON STEEL SCH. 40 MALE NPT
- #5 ELBOWS: CARBON STEEL SCH. 40
- #6 HANGER
- #7 PORT (OPTIONAL):

QTY	MODEL #	SIZE	"A" DIM.	WRK. PSIG	MAX TEST	@ TEMP.	LATERAL OFFSET
	TCH-SDL050012	1/2"	13 1/2"	1100	1650	70°F	2"
	TCH-SDL075012	3/4"	15"	597	895	70°F	2"
	TCH-SDL100012	1"	15 3/4"	580	870	70°F	2"
	TCH-SDL125012	1 1/4"	17 3/4"	441	661	70°F	2"
	TCH-SDL150012	1 1/2"	19 1/4"	370	555	70°F	2"
	TCH-SDL200012	2"	21 1/2"	370	555	70°F	2"
	TCH-SDL250012	2 1/2"	21"	400	600	70°F	2"
	TCH-SDL300012	3"	22 3/4"	288	431	70°F	2"

TEMPERATURE DERATING FACTORS: MULTIPLY X WRK. PSIG									
200° F	250° F	300° F	350° F	400° F	500° F	600° F	700° F	800° F	900° F
0.94	0.92	0.88	0.86	0.83	0.78	0.74	0.7	0.66	0.62

DRAWN BY:

DRAWING NUMBER:

REV:

SIGNATURE:

DATE:

PO NUMBER:

PROJECT:

CUSTOMER:

NOTES: