

DOG LEG FLG 3"

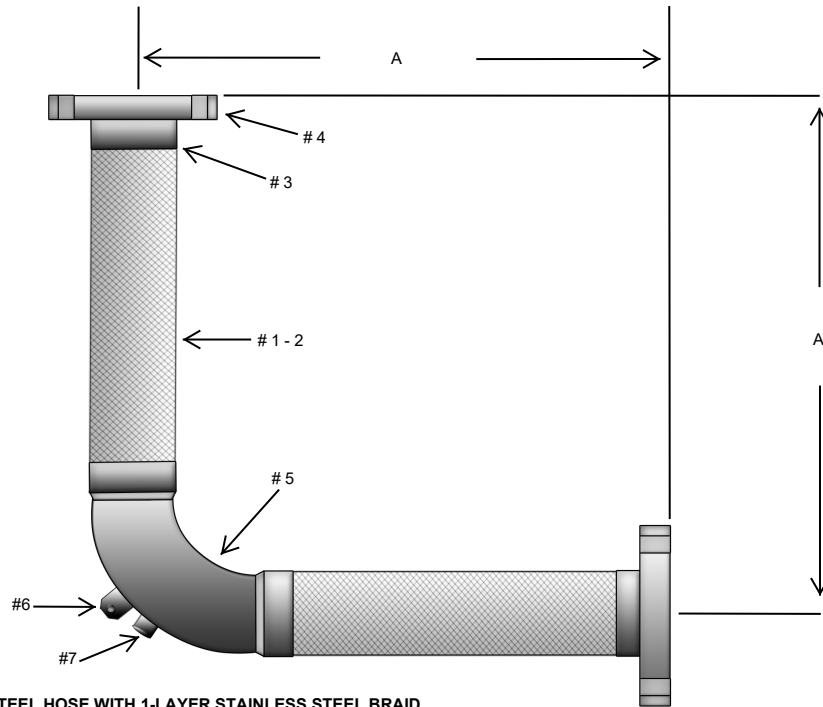

MATERIALS

- #1-2 HOSE: STAINLESS STEEL HOSE WITH 1-LAYER STAINLESS STEEL BRAID
- #3 BRAID BAND: STAINLESS STEEL
- #4 END FITTING: CARBON STEEL PLATE FLANGE
- #5 ELBOWS: CARBON STEEL SCH. 40
- #6 HANGER *12" ID AND LARGER ARE SCHEDULE STANDARD (STD)
- #7 PORT (OPTIONAL):

| QTY | MODEL # | SIZE | "A" DIM. | WRK. PSIG | MAX TEST | @ TEMP. | LATERAL OFFSET |
|-----|---------------|--------|----------|-----------|----------|---------|----------------|
| | TCH-SDL200483 | 2" | 22 1/2" | 370 | 555 | 70°F | 3" |
| | TCH-SDL250483 | 2 1/2" | 21 1/2" | 400 | 600 | 70°F | 3" |
| | TCH-SDL300483 | 3" | 23 1/2" | 288 | 431 | 70°F | 3" |
| | TCH-SDL400483 | 4" | 27" | 250 | 375 | 70°F | 3" |
| | TCH-SDL500483 | 5" | 33" | 200 | 300 | 70°F | 3" |
| | TCH-SDL600483 | 6" | 34 1/2" | 220 | 330 | 70°F | 3" |
| | TCH-SDL800483 | 8" | 43 1/2" | 215 | 323 | 70°F | 3" |
| | TCH-SDL010483 | 10" | 48 1/4" | 200 | 350 | 70°F | 3" |
| | TCH-SDL012483 | *12" | 54" | 160 | 240 | 70°F | 3" |

| TEMPERATURE DERATING FACTORS: MULTIPLY X WRK. PSIG | | | | | | | | | |
|--|--------|--------|--------|--------|--------|--------|--------|--------|--------|
| 200° F | 250° F | 300° F | 350° F | 400° F | 500° F | 600° F | 700° F | 800° F | 900° F |
| 0.94 | 0.92 | 0.88 | 0.86 | 0.83 | 0.78 | 0.74 | 0.7 | 0.66 | 0.62 |

DRAWN BY:

DRAWING NUMBER:

REV:

SIGNATURE:

DATE:

PO NUMBER:

PROJECT:

CUSTOMER:

NOTES: