

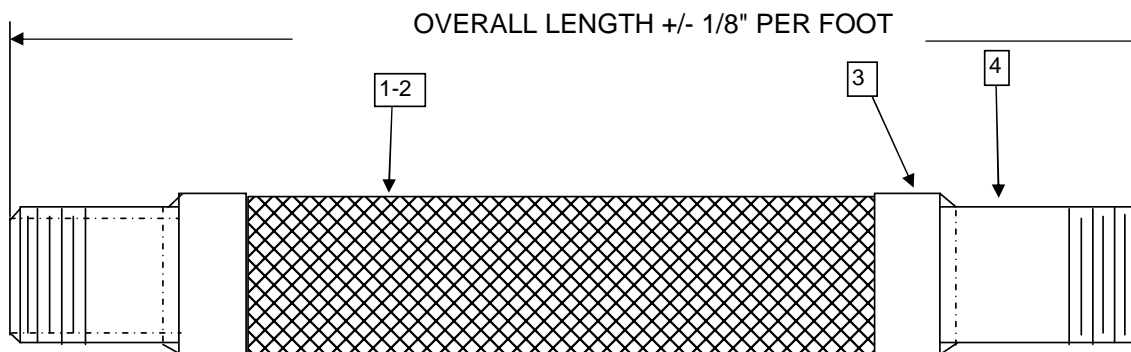

TCHS-MMT



MATERIALS:

#1-2 HOSE: STAINLESS STEEL HOSE WITH 1 LAYER OF STAINLESS BRAID

#3 BRAID COLLAR: T-304 STAINLESS STEEL

#4 MALE NPT: SCH.40 CARBON STEEL

QTY	MODEL NUMBER	SIZE	OVERALL LENGTH	MAX O.D.	WRK. PSIG	@ TEMP	MAX TEST	LATERAL OFFSET
	TCHS-025-MMT	1/4"	6"	.42"	2240	70° F	3360	1/16"
	TCHS-038-MMT	3/8"	10"	.62"	1100	70° F	1650	1/16"
	TCHS-050-MMT	1/2"	6-1/2"	.76"	796	70° F	1194	1/16"
	TCHS-075-MMT	3/4"	7"	1.03"	597	70° F	896	1/16"
	TCHS-100-MMT	1"	8"	1.32"	455	70° F	683	1/16"
	TCHS-125-MMT	1-1/4"	8-1/4"	1.63"	441	70° F	662	1/16"
	TCHS-150-MMT	1-1/2"	9"	1.91"	370	70° F	555	1/16"
	TCHS-200-MMT	2"	10-1/2"	2.46"	370	70° F	555	1/16"
	TCHS-250-MMT	2-1/2"	12"	3.1"	570	70° F	855	1/16"
	TCHS-300-MMT	3"	12"	3.86"	450	70° F	675	1/16"
	TCHS-400-MMT	4"	14"	4.95"	285	70° F	428	1/16"
	TCHS-500-MMT	5"	16"	6"	210	70° F	315	1/16"
	TCHS-600-MMT	6"	16"	7"	240	70° F	360	1/16"

TEMPERATURE DERATING FACTORS: MULTIPLY X WRK. PSIG

200° F	250° F	300° F	350° F	400° F	500° F	600° F	700° F
0.94	0.92	0.88	0.86	0.83	0.78	0.74	0.7

CUSTOMER:

PROJECT:

ENGINEER:

PO#:

TWIN CITY HOSE, INC 20615 COMMERCE BLVD. ROGERS, MN 55374

Phone 800-670-9475 Fax 763-428-5111 www.twincityhose.com