

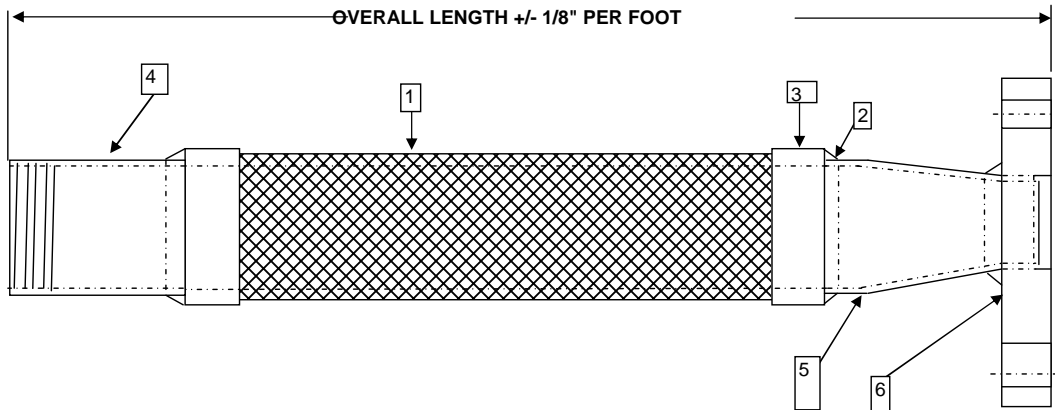

## RCMF



**MATERIALS:**

#1 HOSE & BRAID: T-321 STAINLESS STEEL HOSE & 1 LAYER STAINLESS STEEL BRAID

#2 #3 BRAID COLLAR: STAINLESS STEEL HELI-ARC WELD  
T-304 STAINLESS STEEL BRAID COLLAR

#4 #6 FITTINGS: 150# CARBON STEEL SCH.40 MALE NPT  
150# CARBON STEEL PLATE FLANGE-FLAT FACE REDUCED END

#5 REDUCER: SCH 40 CARBON STEEL CONCENTRIC WELD REDUCER

QTY	MODEL NUMBER	DESCRIPTION	WRK. PSI	@ TEMP	LATERAL	MALE END	FLANGE END
	RCMF0806	8"X6"X20.75" OAL REDUCER	217	70° F	1/4"	8"	6"
	RCMF0805	8"X5"X20.75" OAL REDUCER	217	70° F	1/4"	8"	5"
	RCMF0804	8"X4"X20.75" OAL REDUCER	217	70° F	1/4"	8"	4"
	RCMF0605	6"X5"X19.75" OAL REDUCER	240	70° F	3/8"	6"	5"
	RCMF0604	6"X4"X19.75" OAL REDUCER	240	70° F	3/8"	6"	4"
	RCMF0603	6"X3"X19.75" OAL REDUCER	240	70° F	3/8"	6"	3"
	RCMF0504	5"X4"X18.75" OAL REDUCER	210	70° F	3/8"	5"	4"
	RCMF0503	5"X3"X18.75" OAL REDUCER	210	70° F	3/8"	5"	3"
	RCMF0525	5"X2-1/2"X18.75" OAL REDUCER	210	70° F	3/8"	5"	2-1/2"
	RCMF0403	4"X3"X15.8" OAL REDUCER	285	70° F	3/8"	4"	3"
	RCMF0425	4"X2-1/2"X15.8" OAL REDUCER	285	70° F	3/8"	4"	2-1/2"
	RGMF0402	4"X2"X15.8" OAL REDUCER	285	70° F	3/8"	4"	2"
	RCMF0325	3"X2-1/2"X15.75" OAL REDUCER	450	70° F	3/8"	3"	2-1/2"
	RCMF0302	3"X2"X15.75" OAL REDUCER	450	70° F	3/8"	3"	2"
	RCMF0315	3"X1-1/2"X15.75" OAL REDUCER	450	70° F	3/8"	3"	1-1/2"
	RCMF2502	2-1/2"X2"X15.75" OAL REDUCER	570	70° F	3/8"	2-1/2"	2"
	RCMF2515	2-1/2"X1-1/2"X15.75" OAL REDUCER	570	70° F	3/8"	2-1/2"	1-1/2"
	RCMF2512	2-1/2"X1-1/4"X15.75" OAL REDUCER	570	70° F	3/8"	2-1/2"	1-1/4"
	RCMF2015	2"X1-1/2"X15.75" OAL REDUCER	450	70° F	3/8"	2"	1-1/2"
	RCMF2012	2"X1-1/4"X15.75" OAL REDUCER	450	70° F	3/8"	2"	1-1/4"

**TEMPERATURE DERATING FACTORS: MULTIPLY X WRK PSIG**

200° F	250° F	300° F	350° F	400° F	500° F	600° F	700° F
0.94	0.92	0.88	0.86	0.83	0.78	0.74	0.7

<b>CUSTOMER:</b>	
<b>PROJECT:</b>	
<b>ENGINEER:</b>	
<b>PO#:</b>	

TWIN CITY HOSE, INC 20615 COMMERCE BLVD. ROGERS, MN 55374

Phone 800-670-9475 Fax 763-428-5111 www.twincityhose.com