

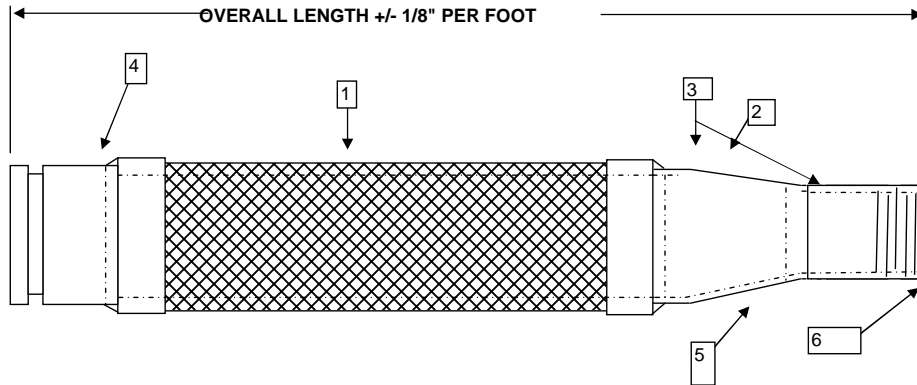

RCGM



MATERIALS:

#1 HOSE & BRAID: T-321 STAINLESS STEEL HOSE & 1 LAYER STAINLESS STEEL BRAID

#2 #3 BRAID COLLAR: STAINLESS STEEL HELI-ARC WELD
T-304 STAINLESS STEEL BRAID COLLAR

#4 #6 FITTINGS: SCH. 40 CARBON STEEL GROOVE
SCH.40 CARBON STEEL MALE NPT END

#5 REDUCER: SCH 40 CARBON STEEL CONCENTRIC WELD REDUCER

QTY	MODEL NUMBER	DESCRIPTION	WRK. PSI	@ TEMP	LATERAL OFFSET	GROOVE END SIZE	MALE END SIZE
	RCGG1210	12"X10"X26.5" OAL REDUCER	155	70° F	3/16"	12"	10"
	RCGG1008	10"X8"X24.75" OAL REDUCER	165	70° F	3/16"	10"	8"
	RCGG1006	10"X6"X23.75" OAL REDUCER	165	70° F	3/16"	10"	8"
	RCGG0806	8"X6"X23.75" OAL REDUCER	217	70° F	1/4"	8"	6"
	RCGG0805	8"X5"X23.75" OAL REDUCER	217	70° F	1/4"	8"	5"
	RCGG0804	8"X4"X23.75" OAL REDUCER	217	70° F	1/4"	8"	4"
	RCGG0605	6"X5"X22" OAL REDUCER	240	70° F	3/8"	6"	5"
	RCGG0604	6"X4"X22" OAL REDUCER	240	70° F	3/8"	6"	4"
	RCGG0603	6"X3"X22" OAL REDUCER	240	70° F	3/8"	6"	3"
	RCGG0504	5"X4"X21" OAL REDUCER	210	70° F	3/8"	5"	4"
	RCGG0503	5"X3"X21" OAL REDUCER	210	70° F	3/8"	5"	3"
	RCGG0525	5"X2-1/2"X21" OAL REDUCER	210	70° F	3/8"	5"	2-1/2"
	RCGG0403	4"X3"X18" OAL REDUCER	285	70° F	3/8"	4"	3"
	RCGG0425	4"X2-1/2"X18" OAL REDUCER	285	70° F	3/8"	4"	2-1/2"
	RCGG0402	4"X2"X18" OAL REDUCER	285	70° F	3/8"	4"	2"
	RCGG0325	3"X2-1/2"X18" OAL REDUCER	450	70° F	3/8"	3"	2-1/2"
	RCGG0302	3"X2"X18" OAL REDUCER	450	70° F	3/8"	3"	2"
	RCGG2502	2-1/2"X2"X18" OAL REDUCER	570	70° F	3/8"	2-1/2"	2"
	RCGG2515	2-1/2"X1-1/2"X18" OAL REDUCER	570	70° F	3/8"	2-1/2"	1-1/2"

TEMPERATURE DERATING FACTORS: MULTIPLY X WRK PSIG

200° F	250° F	300° F	350° F	400° F	500° F	600° F	700° F
0.94	0.92	0.88	0.86	0.83	0.78	0.74	0.7

CUSTOMER:	
PROJECT:	
ENGINEER:	
PO#:	

TWIN CITY HOSE, INC 20615 COMMERCE BLVD. ROGERS, MN 55374