

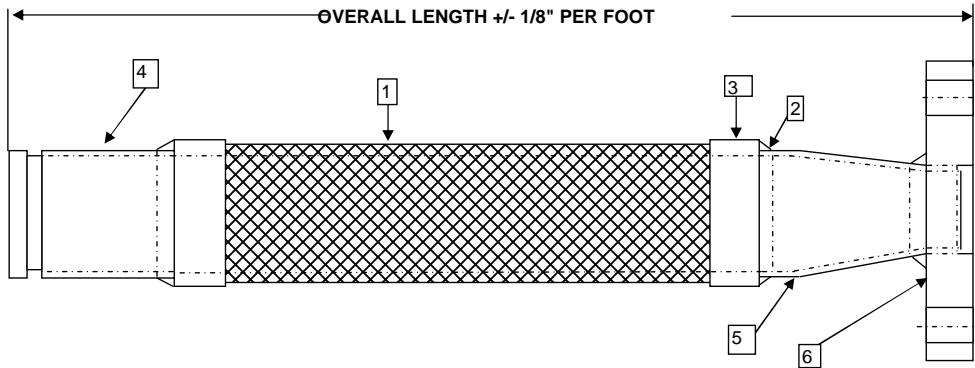

## RCGF



**MATERIALS:**

**#1 HOSE & BRAID:** T-321 STAINLESS STEEL HOSE & 1 LAYER STAINLESS STEEL BRAID

**#2 #3 BRAID COLLAR:** STAINLESS STEEL HELI-ARC WELD  
T-304 STAINLESS STEEL BRAID COLLAR

**#4 #6 FITTINGS:** SCH.40 CARBON STEEL GROOVE REDUCED END  
150# CARBON STEEL PLATE FLANGE-FLAT FACE REDUCED END

**#5 REDUCER:** SCH 40 CARBON STEEL CONCENTRIC WELD REDUCER

| QTY | MODEL NUMBER | DESCRIPTION                     | WRK. PSI | @ TEMP | LATERAL | GROOVE END | FLANGE END |
|-----|--------------|---------------------------------|----------|--------|---------|------------|------------|
|     | RCGF1210     | 12"X10"X23" OAL REDUCER         | 155      | 70° F  | 3/16"   | 12"        | 10"        |
|     | RCGF1008     | 10"X8"X21" OAL REDUCER          | 165      | 70° F  | 3/16"   | 10"        | 8"         |
|     | RCGF1006     | 10"X6"X21" OAL REDUCER          | 165      | 70° F  | 3/16"   | 10"        | 8"         |
|     | RCGF0806     | 8"X6"X21" OAL REDUCER           | 217      | 70° F  | 1/4"    | 8"         | 6"         |
|     | RCGF0805     | 8"X5"X21" OAL REDUCER           | 217      | 70° F  | 1/4"    | 8"         | 5"         |
|     | RCGF0804     | 8"X4"X21" OAL REDUCER           | 217      | 70° F  | 1/4"    | 8"         | 4"         |
|     | RCGF0605     | 6"X5"X19.25" OAL REDUCER        | 240      | 70° F  | 3/8"    | 6"         | 5"         |
|     | RCGF0604     | 6"X4"X19.25" OAL REDUCER        | 240      | 70° F  | 3/8"    | 6"         | 4"         |
|     | RCGF0603     | 6"X3"X19.25" OAL REDUCER        | 240      | 70° F  | 3/8"    | 6"         | 3"         |
|     | RCGF0504     | 5"X4"X18.25" OAL REDUCER        | 210      | 70° F  | 3/8"    | 5"         | 4"         |
|     | RCGF0503     | 5"X3"X18.25" OAL REDUCER        | 210      | 70° F  | 3/8"    | 5"         | 3"         |
|     | RCGF0525     | 5"X2-1/2"X18.25" OAL REDUCER    | 210      | 70° F  | 3/8"    | 5"         | 2-1/2"     |
|     | RCGF0403     | 4"X3"X15.5" OAL REDUCER         | 285      | 70° F  | 3/8"    | 4"         | 3"         |
|     | RCGF0425     | 4"X2-1/2"X15.5" OAL REDUCER     | 285      | 70° F  | 3/8"    | 4"         | 2-1/2"     |
|     | RCGF0402     | 4"X2"X15.5" OAL REDUCER         | 285      | 70° F  | 3/8"    | 4"         | 2"         |
|     | RCGF0325     | 3"X2-1/2"X15.5" OAL REDUCER     | 450      | 70° F  | 3/8"    | 3"         | 2-1/2"     |
|     | RCGF0302     | 3"X2"X15.5" OAL REDUCER         | 450      | 70° F  | 3/8"    | 3"         | 2"         |
|     | RCGF2502     | 2-1/2"X2"X15.5" OAL REDUCER     | 570      | 70° F  | 3/8"    | 2-1/2"     | 2"         |
|     | RCGF2515     | 2-1/2"X1-1/2"X15.5" OAL REDUCER | 570      | 70° F  | 3/8"    | 2-1/2"     | 1-1/2"     |
|     | RCGF0215     | 2"X1-1/2"X15.5" OAL REDUCER     | 570      | 70° F  | 3/8"    | 2"         | 1-1/2"     |
|     | RCGF0212     | 2"X1-1/4"X15.5" OAL REDUCER     | 570      | 70° F  | 3/8"    | 2"         | 1-1/4"     |

**TEMPERATURE DERATING FACTORS: MULTIPLY X WRK PSIG**

|        |        |        |        |        |        |        |        |
|--------|--------|--------|--------|--------|--------|--------|--------|
| 200° F | 250° F | 300° F | 350° F | 400° F | 500° F | 600° F | 700° F |
| 0.94   | 0.92   | 0.88   | 0.86   | 0.83   | 0.78   | 0.74   | 0.7    |

**CUSTOMER:** \_\_\_\_\_

**PROJECT:** \_\_\_\_\_

**ENGINEER:** \_\_\_\_\_

**PO#:** \_\_\_\_\_

TWIN CITY HOSE, INC 20615 COMMERCE BLVD. ROGERS, MN 55374